

 LifeSize[®] Gateway[™]

LifeSize[®] Gateway[™]
Installation Guide

**March 2008
Copyright Notice**

2008 LifeSize Communications Inc, and its licensors. All rights reserved.

LifeSize Communications has made every effort to ensure that the information contained in this document is accurate and reliable, but assumes no responsibility for errors or omissions. Information in this document is subject to change without notice. Companies, names, and data used in examples herein are fictitious unless noted. This document contains copyrighted and proprietary information, which is protected by United States copyright laws and international treaty provisions. No part of the document may be reproduced or transmitted, in any form or by any means, electronic or mechanical, for any purpose, without the express written permission from LifeSize Communications.

Trademark Acknowledgments

LifeSize® is the trademark of LifeSize Communications Inc. All other trademarks are the property of their respective owners.

Patent Notice

For patents covering LifeSize® products, refer to <http://www.lifesize.com/support/legal>.

Contacting Customer Support

If you have questions, concerns, or need assistance, contact your LifeSize Channel Partner.

Providing Customer Feedback

LifeSize Communications welcomes your comments regarding our products and services. If you have feedback about this or any LifeSize product, please send it to feedback@lifesize.com. Contact information for LifeSize Communications is as follows:

Method	Address
Internet	http://www.lifesize.com
E-mail	support@lifesize.com
Phone	(877) LIFESIZE or (877) 543-3749 (512) 347-9300
Fax	(512) 347-9301

CONTENTS

About This Manual

Related Documentation vii

1 *Functionality*

About LifeSize Gateway Products	1
About the Gateway-PRI	1
About the Gateway-Serial	1
About Gateway Features	2
About LifeSize Gateway Applications and Topologies	8
About Multimedia Conferencing	9
About Point-to-Point Conferencing	10
About Multipoint Conferencing	10
About Gateway IP Network Connections	11
About Gateway ISDN Network Connections	11
About Gateway Encryption	13
About Conferencing via Leased Lines	14
About IP-to-Legacy MCU Conferencing	14
About LifeSize Gateway Functionality	15
About PRI Gateway Call Handling Capacity	15
About Gateway Call Bandwidth Overhead	15
Resource Allocation across E1/T1 Lines	16
About Peer-to-Peer Connectivity	16

2 *Setting Up Your LifeSize Gateway*

Physical Description	18
Front Panel	18

Gateway-PRI Rear Panel	19
Gateway-Serial RTM	20
Preparing for Installation	20
Verifying the Package Contents	21
Mounting the LifeSize Gateway Unit in a 19-inch Rack	21
LifeSize Gateway Unit Initial Configuration	22
Connecting to a PC	23
Setting the IP Address	23
Changing the Configuration Tool Login Password	26
Connecting the LifeSize Gateway Unit to the LAN	27
Connecting Serial Lines to the Gateway	28
Serial Gateway Cable Connections and Pin-outs	28
Physical Description of DTE Cables	28
Data Interface Cable Pin-out Configurations	34
Data Interface Pin Layouts	36
DB-25 Connector	38
Signaling Interface Cable Pin-out Configuration	39
Signaling Interface Pin Layout	40
Managing and Monitoring the LifeSize Gateway Unit	41
SNMP Management	41
Local Port Monitoring Connections	41
Performing Software Upgrades	41
Accessing the LifeSize Gateway Administrator Interface	42
Registering the Online Help	43
3 <i>Using the LifeSize Software Upgrade Utility</i>	
Introduction	45
Launching the Utility	46
Upgrading Software	46
4 <i>Cable Connections and Pin-outs</i>	
Unit RS-232 9-Pin Serial Port	50
RJ-45 8-Pin IP Network Port	50

	RJ-45 Serial Port Adapter Cable	51
	ISDN Port	51
5	<i>Technical Specifications</i>	
	Technical Specifications Table	53
	<i>Index</i>	57

ABOUT THIS MANUAL

RELATED DOCUMENTATION

The [LifeSize Gateway Installation Guide](#) describes how to install, configure and monitor LifeSize Gateways.

The LifeSize Gateway documentation set is available on the LifeSize Utilities and Documentation CD-ROM and includes manuals and online helps. The manuals are available in PDF format.

Note You require Adobe Acrobat Reader version 5.0 or later to open the PDF files. You can download Acrobat Reader free of charge from www.adobe.com.

This manual uses the following conventions:

Convention	Description
Blue Headings in Upper Case	Level 1 headings introducing major sections.
	Pointing hand icon introduces a procedure.
orange link	Live links appear in orange.

1

FUNCTIONALITY

This section introduces the LifeSize Gateway, and includes the following topics:

- [About LifeSize Gateway Products](#)
- [About Gateway Features](#)
- [About LifeSize Gateway Applications and Topologies](#)
- [About LifeSize Gateway Functionality](#)

ABOUT LIFESize GATEWAY PRODUCTS

LifeSize Gateway series consists of the following products:

- Gateway-PRI (see [About the Gateway-PRI](#))
- Gateway-Serial (see [About the Gateway-Serial](#))

ABOUT THE GATEWAY-PRI

The Gateway-PRI enables audio, video, and data communication between H.320 endpoints that connect through ISDN, and H.323 endpoints that connect through a packet-based network. For voice-over-IP, the Gateway-PRI enables PSTN voice callers to connect from the ISDN network to IP voice callers. The Gateway-PRI supports two PRI ISDN ports.

ABOUT THE GATEWAY-SERIAL

The Gateway-Serial supports multimedia conferencing over IP by translating between H.323 and serial protocols. With the help of an Imux, the LifeSize Gateway can also translate between H.323 and H.320 protocols.

The LifeSize Gateway offers a serial leg for multimedia conferencing over IP by providing an interface for legacy endpoints with serial interfaces, encryption/decryption devices, satellite networks and leased line services.

ABOUT GATEWAY FEATURES

Table 1-1 lists the major features of the LifeSize Gateway.

Table 1-1 Gateway Feature Summary

Feature	Description
Interoperability	The LifeSize Gateway provides a high degree of interoperability with other H.323 compliant gateways, gatekeepers, terminals, proxy, and Multipoint Control Unit (MCU) products by being based on the H.320 standard and H.323 protocol stack.
Web-based management	The LifeSize Gateway features the LifeSize Gateway interface. This is a web interface used to configure and monitor the LifeSize Gateway. You can view and modify all aspects of the LifeSize Gateway configuration from a remote location using a Java-enabled web browser.
SNMP management	The LifeSize Gateway features Simple Network Management Protocol (SNMP) management that supports all aspects of monitoring, diagnostics, configuration, and trapping.
Diagnostics	The LifeSize Gateway features front and rear panel LED indicators that display status for the unit. You can also access remote diagnostics of the unit through the LifeSize Gateway interface, Telnet, SNMP, or a serial port.
Network load balancing	The LifeSize Gateway supports load balancing on the network by communicating with a gatekeeper through H.323 RAI (Resource Available Indication)/RAC (Resource Available Confirmation) messages.
T.120 data collaboration	The LifeSize Gateway supports data transfers in calls between ISDN and IP by using high speed T.120 in HMLP and VarMLP formats.
Quality of service (QoS)	The LifeSize Gateway features configurable coding of media packets to achieve QoS routing priority on the Internet Protocol (IP) network. The Type of Service (ToS) bits of the IP datagram header can be configured for priority level.

Table 1-1 Gateway Feature Summary (continued)

Feature	Description
Dial plan	The LifeSize Gateway supports a simplified dial plan for outbound dialing using a single universal prefix. Using the dial plan, the LifeSize Gateway automatically detects the capabilities received in the Setup message from the IP endpoint and sets the same bit rate for the ISDN (or serial interface) side of the call.
Direct dialing and call routing	<p>The LifeSize Gateway dial plan supports the following direct dialing and call routing facilities:</p> <ul style="list-style-type: none"> ■ Direct Inward Dialing (DID) <ul style="list-style-type: none"> □ Multiple Subscriber Network (MSN) □ Q.931 Sub-addressing Information Element <p>Gateway-Serial supports DID in DCE mode only.</p> ■ Internal and External Interactive Voice Response (IVR) ■ TCS4 ■ Default extension
Access control	The LifeSize Gateway features password-controlled access to the LifeSize Gateway interface. Up to ten different administrator access profiles can be defined for the LifeSize Gateway.
DTMF translation	The LifeSize Gateway supports translation between in-band Dual Tone Multi-Frequency (DTMF) signals (on the ISDN side) and out-of-band H.245 messages (on the IP side). DTMF translation occurs for voice and video calls.
Dual video	The LifeSize Gateway supports H.239 standards-based dual video and TANDBERG DuoVideo technology. Dual video streams enable a screen to carry video images from one source while simultaneously displaying images from a second source.

Table 1-1 Gateway Feature Summary (continued)

Feature	Description
Conceal caller ID	The LifeSize Gateway supports a conceal caller ID feature that instructs the gatekeeper to conceal the identity of the calling endpoint on the IP or ISDN network, whether the presentation restricted feature is enabled or not.
H.323 fast start	The LifeSize Gateway H.323 fast start feature enables endpoints to join a voice conference in the LifeSize Gateway more quickly.
ISDN rollover (available in Gateway-PRI only)	The LifeSize Gateway features ISDN rollover. In this feature, the LifeSize Gateway sends a “busy out” channel request to the PSTN switch when the current PRI connection is left with less than a predefined number of available B channels. The PSTN switch “rolls over” to the next available gateway.
Network Specific Facility (available in Gateway-PRI only)	The LifeSize Gateway provides support for Network Specific Facility Information Elements (NSF IEs) which enable system administrators to specify to service providers the equipment, service, or network through which they want a call routed.
ISDN connection failure	The LifeSize Gateway responds to ISDN connection failure events, by unregistering from its gatekeeper. The gatekeeper is forced to send new IP-to-ISDN calls through a different gateway, thus ensuring high call completion rates. The LifeSize Gateway re-registers to the gatekeeper when the ISDN connection is restored.
Downspeeding	The LifeSize Gateway features downspeeding functionality. In the downspeeding feature, the LifeSize Gateway attempts to reconnect a disconnected video call either at a lower bandwidth or as a voice call. Downspeeding contributes to a higher percentage of call completion on the network. The LifeSize Gateway supports downspeeding at call setup and in mid-call.
Multiple trap server support	The LifeSize Gateway supports up to three SNMP trap servers.

Table 1-1 Gateway Feature Summary (continued)

Feature	Description
H.239 support	The LifeSize Gateway supports the H.239 protocol in ISDN-to-IP calls and in IP-to-ISDN calls.
Encryption support	The LifeSize Gateway supports H.235-compliant AES 128 encryption for calls over IP networks, and H.233 and H.234-compliant AES 128 encryption for calls over ISDN networks.
H.243 Conference Control support	The LifeSize Gateway supports the H.243 protocol in ISDN-to-IP calls and in IP-to-ISDN calls. The LifeSize Gateway identifies the protocol version that an IP endpoint uses and sends H.239 capabilities only to those endpoints working with protocol version 4.0 or later.
Peer-to-peer connectivity	The LifeSize Gateway supports connectivity to the IP network through a gatekeeper, or directly to a peer device.
IP network connections	The LifeSize Gateway has one 10/100Base-T Ethernet IP port (on the front panel) and connects to an IP segment through a direct connection to a network switch.

Table 1-2 lists features for specific LifeSize Gateways.

Table 1-2 LifeSize Gateway Feature Specifics

Feature	Gateway-PRI	Gateway-Serial
Supported ports	2 PRI ISDN ports	4 serial ports
Supported video conferencing protocols	H.320, H.323 (v4.0)	
Supported audio codecs	The term <i>audio transcoded video calls</i> refers to the process whereby an <i>audio</i> stream in a multimedia call can be transcoded from one codec type to another. Basic and advanced audio coding supported codecs: G.711, G.722, G.722.1, G.723.1, G.728	
Audio Transcoding	G.711 (ISDN) <> G.723.1 (IP) for up to 60 voice channels.	Transcoding for the 4 supported multimedia calls.

About Gateway Features

Table 1-2 LifeSize Gateway Feature Specifics (continued)

Feature	Gateway-PRI	Gateway-Serial
	G.711 (IP) < > G.728 (ISDN) for up to 20 audio transcoded video channels.	
	The LifeSize Gateway automatically performs A-Law G.711-to-μ-Law G.711 translation between the IP and ISDN sides if needed.	
	<hr/> Note When your LifeSize unit includes both a LifeSize Gateway and a LifeSize Multipoint, G.728 transcoding is supported on the LifeSize Multipoint only. <hr/>	
Supported video protocols	H.261, H.263, H.263+ (Annexes F, J and N), H.263++ (Annex W), H.264	
Supported video resolutions	VGA, XGA, SVGA, SIF, 4SIF, CIF, QCIF, 4CIF, 16CIF	
Supported bandwidths (Kbps)	56, 64, 112, 128, 168, 192, 224, 256, 280, 320, 336, 384, 448, 512, 672, 768, 1288, 1472, 1680 and 1920	56, 64, 112, 128, 168, 192, 224, 256, 280, 320, 336, 384, 448, 512, 672, 768, 1288, 1472 and 1920
	<hr/> Note Bandwidth rates of 256 Kbps and up support the G.722 audio codec. <hr/>	

Table 1-2 LifeSize Gateway Feature Specifics (continued)

Feature	Gateway-PRI	Gateway-Serial
Call handling capabilities	<p>For 1 x PRI T1 line: 23 ports (voice) 23 ports 1B (video and data) 11 ports 2B (video and data) 3 ports 6B (video and data)</p> <p>For 2 x PRI T1 lines: 46 ports (voice) 30 ports 1B (video and data) 23 ports 2B (video and data) 7 ports 6B (video and data)</p> <p>For 1 x PRI E1 line: 30 ports (voice) 30 ports 1B (video and data) 15 ports 2B (video and data) 5 ports 6B (video and data)</p> <p>For 2 x PRI E1 lines: 60 ports (voice) 30 ports 1B/2B (video and data) 10 ports 6B (video and data)</p>	1 call per serial connection, up to a maximum bandwidth of 1920 Kbps per port.
Line quality	Supports line echo cancellation, H.323 Fast Start and DTMF detection for voice and video calls.	Supports line echo cancellation and DTMF detection for voice calls.
IP network connection	110/100Base-T Ethernet IP UTP connection (on the front panel).	
Serial control port (DB-9) connection	RS-232 DTE 9-pin D-type connection on front panel for connection to a PC terminal or an external modem.	
Supported media protocols	N/A	V.35, RS-449, EIA-530, EIA-530A
Supported signaling protocols	5ESS and 4ESS, DMS100, National ISDN, Euro-ISDN, VN6 Dialing (France), NTT (Japan), Hong Kong Dialing (Hong Kong), Support for Taiwan PRI system.	RS-366, Manual Control, Data Triggered.
Supported media + signaling combinations	N/A	RS-449 + RS-366 V.35 + RS-366 EIA-530 + RS-366 EIA-530A + RS-366

About LifeSize Gateway Applications and Topologies

Table 1-2 LifeSize Gateway Feature Specifics (continued)

Feature	Gateway-PRI	Gateway-Serial
Encryption interoperability	N/A	KIV-7, KG-194
PRI interface	Configurable E1/T1 PRI network interface. Support for fractional E1/T1 channel selection. Configurable as terminal side (TE) or network side (NT) device. Configurable Long Haul PRI module (supported in Japan only).	N/A
Switch information	Numbering Plan Identifier (NPI), Type of Number (TON) and Network Specific Facility (NSF) information elements are configurable per PRI port.	N/A
Bonding calls	Internal Imux providing calls at 128 Kbps (2B) up to full PRI of 1472 Kbps (23B) for T1 and up to full PRI of 1920 Kbps (30B) for E1 using bonding mode 1. Parallel dialing for bonded calls.	N/A
Internal IVR capacity	30 simultaneous calls	4 simultaneous calls

ABOUT LIFESIZE GATEWAY APPLICATIONS AND TOPOLOGIES

The LifeSize Gateway supports multimedia conferencing by translating between H.323 and H.320 protocols. Examples of network applications that use the LifeSize Gateway include:

- Multimedia conferencing (see [About Multimedia Conferencing](#) on page 9)
- Point-to-Point conferencing (see [About Point-to-Point Conferencing](#) on page 10)
- Multipoint conferencing (see [About Multipoint Conferencing](#) on page 10)
- IP networking (see [About Gateway IP Network Connections](#) on page 11)
- ISDN networking (see [About Gateway ISDN Network Connections](#) on page 11)

- Encrypted videoconferencing (see [About Gateway Encryption](#) on page 13)
- Conferencing over leased lines (see [About Conferencing via Leased Lines](#) on page 14)
- Communicating with legacy MCU equipment (see [About IP-to-Legacy MCU Conferencing](#) on page 14)

ABOUT MULTIMEDIA CONFERENCING

The LifeSize Gateway-PRI enables H.323 endpoints on the IP network to communicate with an H.320 terminal, an ISDN phone, or a regular phone on a circuit-switched public network without having to connect directly to these networks. The LifeSize Gateway allows all IP network terminals to support video conferences without connecting every desktop computer to an ISDN line (see [Figure 1-1](#)).

Figure 1-1 Multimedia Conferencing through the Gateway

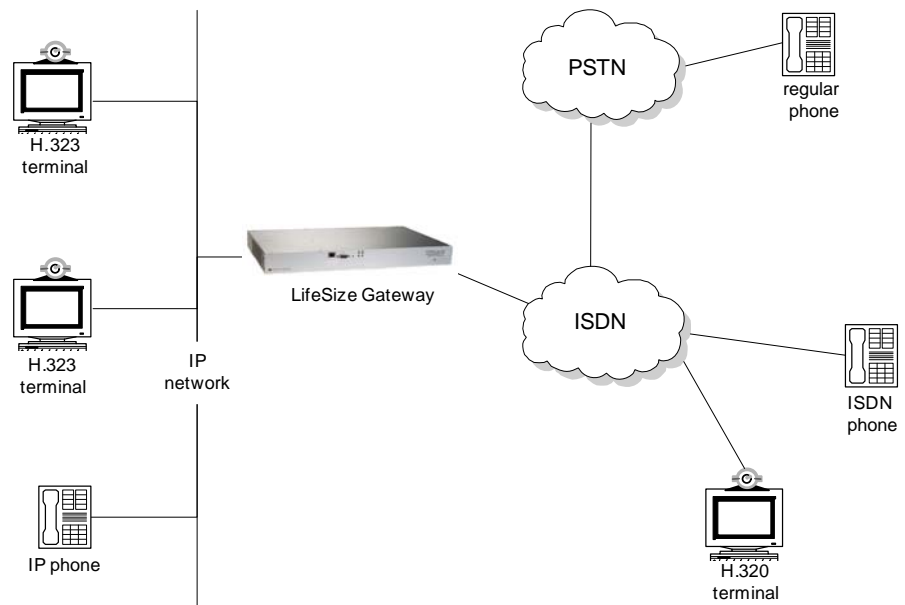

Typical multimedia conferencing applications include:

- Business video conferencing
- Distance learning
- Telemedicine

About LifeSize Gateway Applications and Topologies

- Video-enabled call centers
- Telecommuting

ABOUT POINT-TO-POINT CONFERENCING

The LifeSize Gateway-PRI enables direct video, voice, and data communication between an H.320 (ISDN) terminal and H.323 (IP) terminals at bandwidths of up to 1472 Kbps (23B bonding for T1) and up to 1920 Kbps (30B bonding for E1) (see [Figure 1-2](#)).

Figure 1-2 Point-to-Point Conferencing through the Gateway



ABOUT MULTIPOINT CONFERENCING

Together with the LifeSize Multipoint, the LifeSize Gateway-PRI enables H.320 ISDN terminals to participate in a mixed ISDN-IP multipoint multimedia conference with IP network endpoints (see [Figure 1-3](#)).

For example, when an H.320 ISDN terminal wants to participate in a multipoint conference with H.323 IP endpoints, the H.320 ISDN terminal can either join the multipoint conference by dialing to the LifeSize Gateway, or be invited into the conference by one of the participating IP endpoints. In either case, the LifeSize Gateway connects the ISDN terminal to the LifeSize Multipoint, enabling it to participate in the multipoint conference.

Figure 1-3 *Mixed ISDN-IP Multipoint Multimedia Conference*

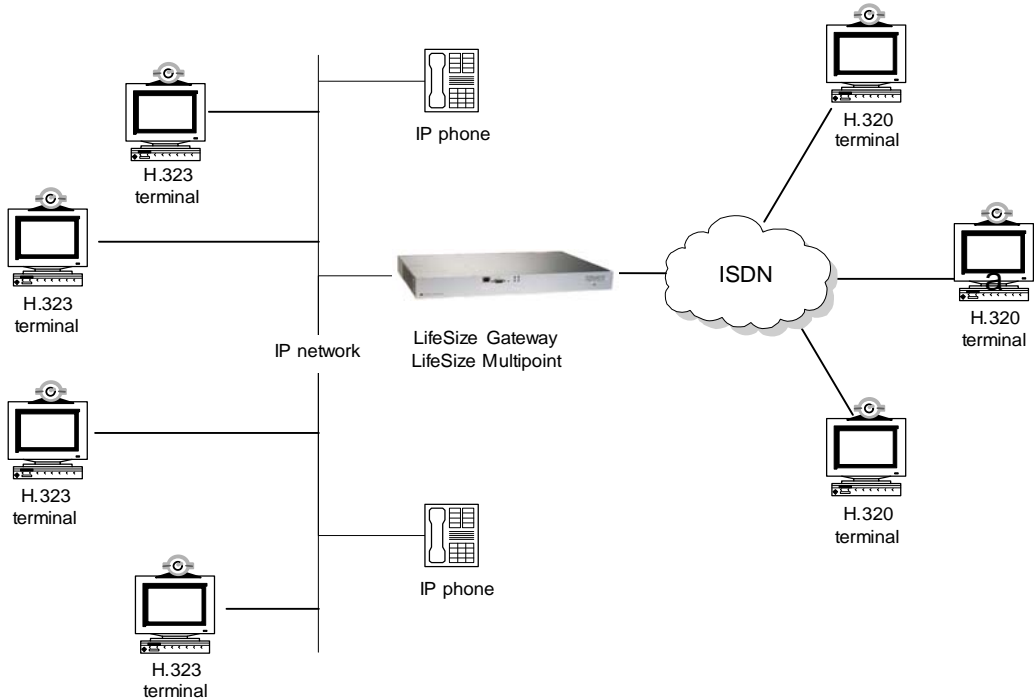

ABOUT GATEWAY IP NETWORK CONNECTIONS

The LifeSize Gateway-PRI features one 10/100Base-T Ethernet IP port (on the front panel) and connects to an IP segment through a direct connection to a network switch.

ABOUT GATEWAY ISDN NETWORK CONNECTIONS

The LifeSize Gateway-PRI features configurable E1/T1 PRI ISDN connections. When configured as an E1 connection, each port provides 30 B channels and one D signaling channel. When configured as a T1 connection, each port provides 23 B channels and one D signaling channel. The type of line available depends on your local ISDN provider. You configure the LifeSize Gateway PRI port to an E1 or T1 interface accordingly. In addition, you can choose to activate only specific channels by using fractional channel selection.

About LifeSize Gateway Applications and Topologies

PRI GATEWAYS

You can connect the Gateway-PRI directly to a PRI line provided by your local ISDN provider (as shown in [Figure 1-4](#)), or to a local private branch exchange (PBX) that provides the PRI connection (as shown in [Figure 1-5](#)).

Figure 1-4 Connecting the PRI Gateway Directly to a Central Office Switch

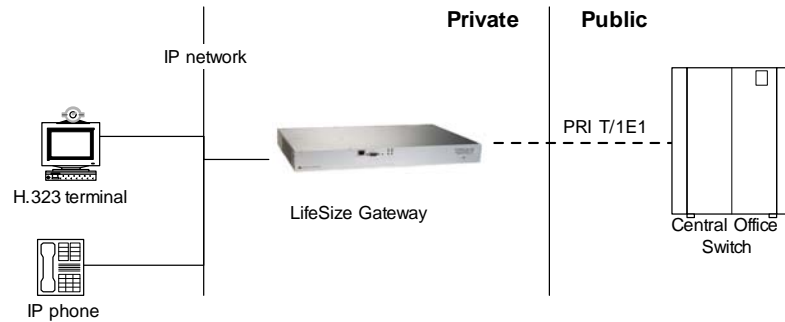
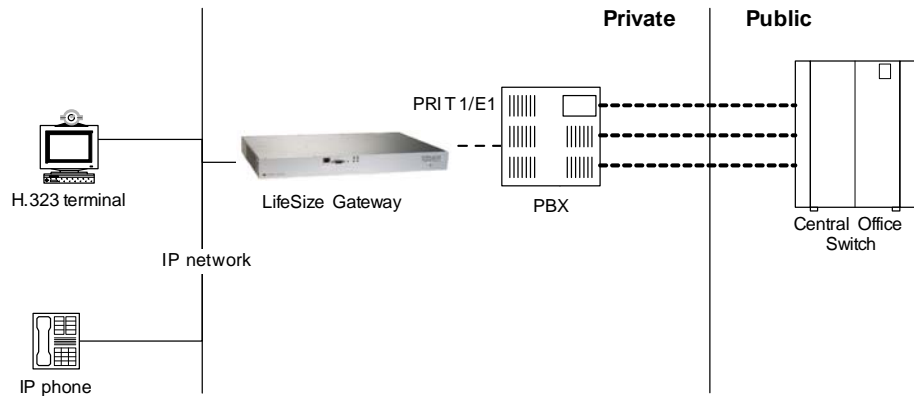

Figure 1-5 Connecting the PRI Gateway to a PBX that Provides a PRI Line



ABOUT GATEWAY ENCRYPTION

The Gateway-Serial enables encrypted videoconferencing between H.323 endpoints on the IP network and endpoints on remote sites by connecting to external encryption/decryption devices via serial interfaces (as shown in [Figure 1-6](#)). The Gateway-Serial also enables encrypted videoconferencing via satellite with or without RS-366 signaling (as shown in [Figure 1-7](#)).

Figure 1-6 Encrypted Videoconferencing

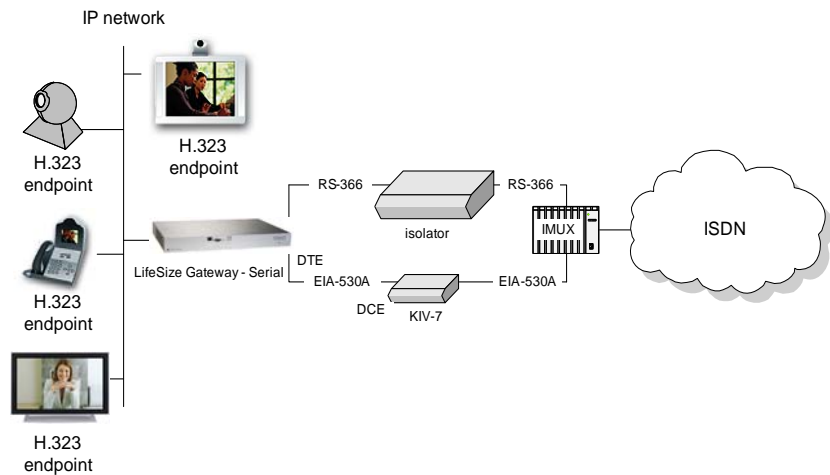
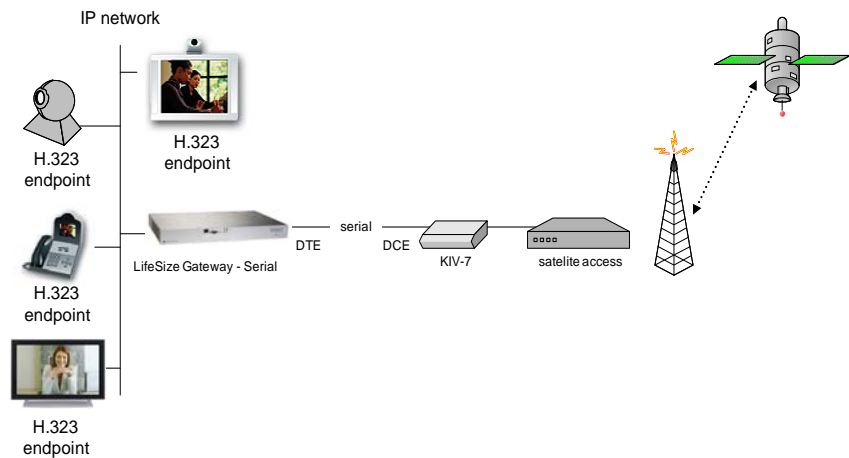

Figure 1-7 Encrypted Videoconferencing via Satellite



ABOUT CONFERENCING VIA LEASED LINES

The Gateway-Serial enables conferencing between H.323 endpoints on IP networks connected via a leased line (as shown in [Figure 1-8](#)).

Figure 1-8 Conferencing via Leased Lines

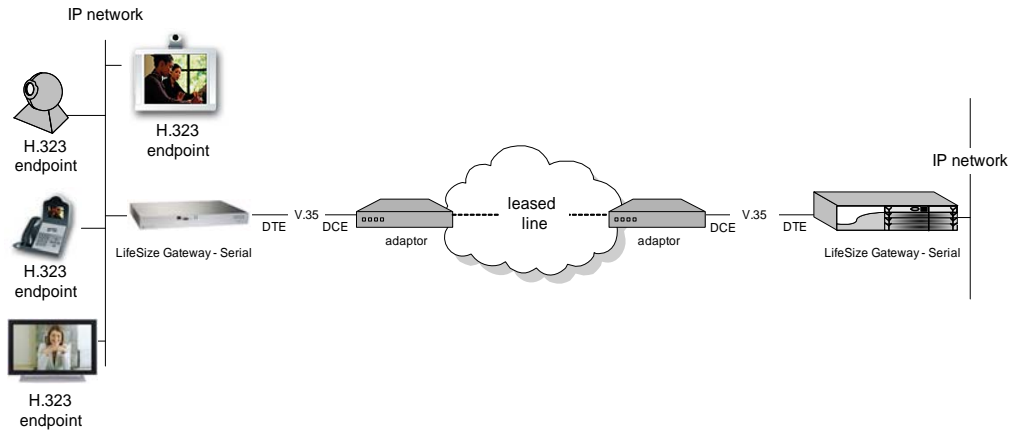

ABOUT IP-TO-LEGACY MCU CONFERENCING

The Gateway-Serial provides an IP-to-serial interface for communication with legacy MCU equipment (as shown in [Figure 1-9](#)).

Figure 1-9 IP-to-Serial Interface Communication via Legacy MCU

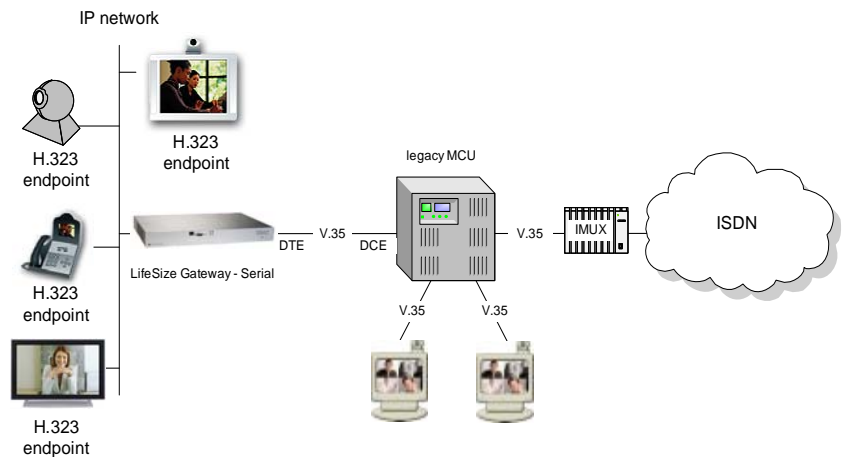

ABOUT LIFESIZE GATEWAY FUNCTIONALITY

This section discusses the following topics:

- [About PRI Gateway Call Handling Capacity](#) on page 15
- [About Gateway Call Bandwidth Overhead](#) on page 15
- [About Peer-to-Peer Connectivity](#) on page 16

ABOUT PRI GATEWAY CALL HANDLING CAPACITY

Table 1-3 lists the maximum call handling capacity of the Gateway-PRI for different types of calls.

Table 1-3 PRI Gateway Call Handling Capacity

Call Type	Maximum Number of Calls Using 1 x E1 PRI Line	Maximum Number of Calls Using 1 X T1 PRI Line	Maximum Number of Calls Using 2 x E1 PRI Lines	Maximum Number of Calls Using 2 x T1 PRI Lines
voice (64 Kbps)	30	23	60	46
2B video (128 Kbps)	15	11	30	23
6B video (384 Kbps)	5	3	10	7
12B video (768 Kbps)	2	1	5	3

Note Enabling ISDN-to-IP DTMF detection in the Gateway-PRI for video calls reduces the number of supported calls by half.

ABOUT GATEWAY CALL BANDWIDTH OVERHEAD

According to the H.320 standard, the available bandwidth allocated to a call at any given bit rate will always be slightly less than the stated maximum for the following reasons:

- All stated maximum call bandwidths include provision for control, audio, video, and data traffic.
- Video traffic on the ISDN side contains additional bits for error correction purposes which also consume bandwidth. Video traffic on the IP side does not include this additional load.
- Opening an audio channel further reduces the bandwidth available to the video traffic.

For example, a call at 384 Kbps actually has only 363 Kbps available to it. Control and error correction account for the remaining 21 Kbps.

RESOURCE ALLOCATION ACROSS E1/T1 LINES

The LifeSize Gateway can allocate bandwidth resources to calls across separate E1 or T1 connections to maximize bandwidth capacity in cases where there is not enough capacity for a call on a single E1 or T1 connection, but where sufficient capacity does exist when remaining capacity on both E1/T1 lines is combined.

For example, a LifeSize Gateway using two T1 lines can support three 6B calls on each T1 line, with 320 Kbps spare capacity per line:

- Each T1 line provides 23 B channels.
- Each B channel supports 64 Kbps
- Each T1 line supports $23 \times 64 = 1472$ Kbps
- Each 6B call requires $6 \times 64 = 384$ Kbps
- Each T1 line supports $1472/384 = 3$ 6B calls + 320 Kbps spare

The LifeSize Gateway processes an additional 6B call requiring a further 384 Kbps by taking bandwidth resources from each of the two T1 lines, both of which have 320 Kbps available. In this way, the LifeSize Gateway spreads the call over both T1 lines.

ABOUT PEER-TO-PEER CONNECTIVITY

The LifeSize Gateway supports the following types of connectivity to the IP network

- Through a gatekeeper
- Directly to a peer device such without the need for a gatekeeper.

2

SETTING UP YOUR LIFESIZE GATEWAY

This section introduces the LifeSize Gateway solution and details the components that LifeSize Gateway includes, and includes the following topics:

- [Physical Description](#)
- [Preparing for Installation](#)
- [Verifying the Package Contents](#)
- [Mounting the LifeSize Gateway Unit in a 19-inch Rack](#)
- [LifeSize Gateway Unit Initial Configuration](#)
- [Connecting the LifeSize Gateway Unit to the LAN](#)
- [Connecting Serial Lines to the Gateway](#)
- [Serial Gateway Cable Connections and Pin-outs](#)
- [Managing and Monitoring the LifeSize Gateway Unit](#)
- [Accessing the LifeSize Gateway Administrator Interface](#)
- [Registering the Online Help](#)

PHYSICAL DESCRIPTION

FRONT PANEL

This section provides a physical description of the LifeSize Gateway units.

Figure 2-1 shows the front panel of the LifeSize Gateway unit. Table 2-1 describes the components of the front panel.

Figure 2-1 LifeSize Gateway Front Panel

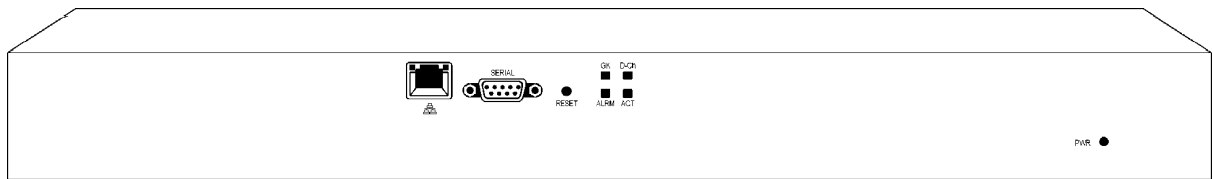

Table 2-1 Front Panel Components

Component	Description
Ethernet connector	An RJ-45 connector that provides the primary Ethernet connection for the IP network port.
SERIAL connector	A DB-9 connector that allows you to connect a PC terminal for local configuration.
RST button	Allows you to reset the LifeSize Gateway unit manually.
GK LED	Lights green when the LifeSize Gateway unit is registered with a gatekeeper.
D-Ch LED	Lights green when a PRI or serial line is enabled and a carrier signal is detected
ACT LED	Lights green to indicate that there are active calls in the LifeSize Gateway unit.
ALRM LED	Lights green to indicate that an error has occurred and the LifeSize Gateway unit requires resetting.
ETHERNET LEDs	The top part of the Ethernet connector contains two LED indicators. The left-hand LED lights green when the local IP network link is active. The right-hand LED lights green if the connection speed is 100 Mbps, and is off when the connection speed is 10 Mbps.

GATEWAY-PRI REAR PANEL

Figure 2-2 shows the rear panel components of the Gateway-PRI unit. Table 2-2 describes these components.

Figure 2-2 Gateway-PRI: Rear Panel



Table 2-2 Gateway-PRI Rear Panel Components

Component	Description
ACT LEDs	Lights green to indicate that there are active calls in the LifeSize Gateway on the specified PRI line.
D-Ch LEDs	Lights green to indicate that the PRI line is enabled and a carrier signal is detected.
ALRM LEDs	Displays alarm events for the PRI line. <ul style="list-style-type: none"> ■ YELLOW—Lights yellow when there is a loss of frame alignment at the remote side. ■ ORANGE—Lights orange when there is a loss of frame alignment in the LifeSize Gateway.
PRI LINE connectors	RJ-45 connectors that provide the PRI line connections for the specified LifeSize Gateway ISDN PRI port.

GATEWAY-SERIAL RTM

Figure 2-3 shows the rear panel components of the Gateway-Serial unit. Table 2-3 describes these components.

Figure 2-3 Gateway-Serial: Rear Panel

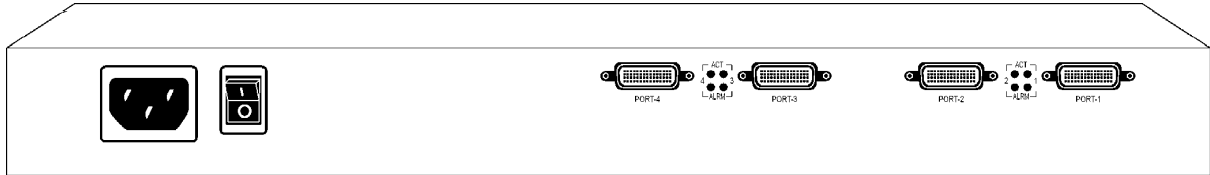

Table 2-3 Gateway-Serial Rear Panel Components

Component	Description
PORT connectors	DB-60 connectors that provide the serial line connections for LifeSize Gateway serial ports 1 to 4.
ACT and ALRM LEDs	ACT lights green to indicate that the specified serial line is currently in use. ALRM lights red to indicate an internal error related to the specified line.

PREPARING FOR INSTALLATION

This section describes the requirements for installing the LifeSize Gateway unit.

- Proper clearance at the sides of the unit to allow adequate ventilation, and at least 20 cm clearance at the back of the unit to allow access to cable connections
- A PC with a serial port and terminal emulation software to assign the LifeSize Gateway unit an IP address
- Dedicated IP address for the LifeSize Gateway unit
- The IP address of the router that the LifeSize Gateway unit will use to communicate across the network
- For an H.323 environment, the IP address of the H.323 gatekeeper with which you want the LifeSize Gateway unit to register
- Available IP network ports on the switch for the LifeSize Gateway unit
- A grounded AC power outlet
- A 10BaseT or 100BaseT LAN cable

- Ambient room temperature range of 32° to 104°F (0° to 40°C)
- Non-condensing relative humidity range of 5% to 90%

VERIFYING THE PACKAGE CONTENTS

Inspect the contents of the box for shipping damage. Report any damage or missing items to your distributor or reseller. [Table 2-4](#) lists the package contents for the LifeSize Gateway unit.

Table 2-4 *Package Contents with LifeSize Gateway Unit*

Product	Contents
Gateway-PRI or Gateway-Serial unit	<ul style="list-style-type: none"> ■ LifeSize Gateway Unit ■ Power cable (depending on customer location) ■ Terminal cable ■ LAN cable ■ Rack mounting kit (two brackets and six screws) ■ Four rubber feet ■ LifeSize Gateway CD-ROM containing product documentation, utilities and online help files.

MOUNTING THE LIFESIZE GATEWAY UNIT IN A 19-INCH RACK

You can optionally mount the LifeSize Gateway unit in a standard 19-inch rack. Two mounting brackets and a set of screws are included in the LifeSize Gateway unit shipping box.



Procedure

- 1 Disconnect all cables including the power cables.
- 2 Place the LifeSize Gateway unit right-side up on a hard flat surface, with the front panel facing you.
- 3 Position a mounting bracket over the mounting holes on each side of the LifeSize Gateway unit, as shown in [Figure 2-4](#).

Mounting the LifeSize Gateway Unit in a 19-inch Rack

Figure 2-4 *Fitting a Bracket for Rack Mounting*

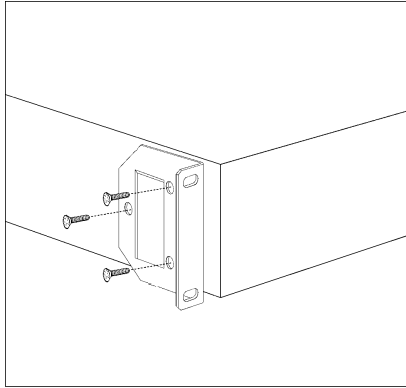

- 4** Pass the screws through the brackets and tighten them into the screw holes on each side of the LifeSize Gateway unit using a suitable screwdriver.
 - 5** Insert the LifeSize Gateway unit into the 19-inch rack.
 - 6** Fasten the brackets to the side rails of the rack.
 - 7** Make sure that the air vents at the sides of the LifeSize Gateway unit are not blocked.
-

LIFESIZE GATEWAY UNIT INITIAL CONFIGURATION

Initial monitoring and administration of the LifeSize Gateway unit are performed from a remote PC via a serial connection. This allows you to access the boot configuration menu of the LifeSize Gateway unit. At power-up, the LifeSize Gateway unit goes through the following boot phases:

- **Auto-boot**—The embedded operating system initializes and displays basic information.
- **Configuration menu**—A 6-second countdown allows you to enter the configuration menu.
- **Initialization**—The LifeSize Gateway unit completes its boot sequence and is ready for operation.

Note You can perform serial port configuration of the LifeSize Gateway unit only at startup, during a short period indicated by a 6-second countdown. Once the initialization phase is complete, the only way you can access the configuration menu is by restarting the LifeSize Gateway unit.

CONNECTING TO A PC

This section describes how to use the serial port connection to configure the LifeSize Gateway unit with an IP address.



Procedure

- 1 Locate the terminal cable shipped with the LifeSize Gateway unit.
- 2 Connect the end labeled **PC** to the serial port on the computer.
- 3 Connect the end labeled **Unit** to the serial port connector on the LifeSize Gateway unit front panel.

Note The PC terminal should have an installed terminal emulation application, such as HyperTerminal.

SETTING THE IP ADDRESS

This section describes how to use the serial port to configure the unit with an IP address and other address information.

The serial port on the LifeSize Gateway unit front panel is used to assign a new IP address to your LifeSize Gateway unit. You must assign the IP address before you connect the LifeSize Gateway unit to the network.

Before You Begin

Gather the items listed in [Table 2-5](#) to assign an IP address to the LifeSize Gateway unit.

Table 2-5 *Requirements for Setting the IP Address*

Requirements	Notes
Dedicated IP address for the LifeSize Gateway unit	
IP address of the default router the LifeSize Gateway unit uses to communicate over the network	
PC with available serial port and terminal emulator software installed	
RS-232 terminal cable (shipped with the unit)	



Procedure

- 1 Connect the supplied terminal cable to the PC terminal.
- 2 Connect the power cable.
- 3 Start the terminal emulation application on the PC.
- 4 Set the communication settings in the terminal emulation application on the PC as follows:
 - Baud rate: 9600
 - Data bits: 8
 - Parity: None
 - Stop bits: 1
 - Flow control: None
- 5 Turn on the power to the LifeSize Gateway unit.

- 6 After the terminal emulator session starts, press the **RST** button on the LifeSize Gateway unit front panel to reset the module.

A log of the auto-boot events and a VxWorks banner scrolls across the computer monitor.

Note When the LifeSize Gateway unit is started for the first time, two VxWorks banners appear. The configuration option appears after the second banner.

- 7 When the message “Press any key to start configuration” appears on the screen, press any key within 6 seconds.

The network configuration **Main** menu appears:

```
Press any Key To start configuration...
```

```
Main menu
```

```
Enter <N> to configure default network port values
```

```
Enter <P> to change the configuration software password
```

```
Enter <A> to display advanced configuration menu
```

```
Enter <Q> to quit configuration menu and start GW
```

Caution If you do not press a key before the countdown ends, the device continues its initialization and you can only configure the device by pressing the **RST** button on the front panel.

- 8 At the prompt, type **N** to configure default network port values and press **Enter**.
- 9 At the Enter IP address for default interface prompt, type the IP address you want to assign to the LifeSize Gateway unit and press **Enter**.

Caution Do not use leading zeros in the IP address.

- 10 At the **Enter Default Router IP Address** prompt, type the IP address of the router associated with the segment in which the unit will be installed and press **Enter**.

Caution Do not use leading zeros in the IP address.

- 11 At the **Enter IP Mask <HEX> for default device** prompt, type the subnet mask as follows:

- Convert the subnet mask IP address to hexadecimal notation, type the hexadecimal number at the prompt, and press **Enter**.

For example, for the subnet mask 255.255.255.0 the hexadecimal value you type is FFFFFFF0.

Note You can use the computer's desktop calculator to convert the subnet mask ID to hexadecimal notation.

- If a subnet mask is not used, press **Enter**.
- 12 Allow the unit to complete the reboot process. A new emulator session begins.
 - 13 Close the terminal emulator session.

CHANGING THE CONFIGURATION TOOL LOGIN PASSWORD



You can use the terminal emulator to change the default password of the default login user before others can use the LifeSize Gateway interface.

Procedure

- 1 Start a terminal emulator session for the LifeSize Gateway unit.
- 2 Press the **RST** button on the front panel of the LifeSize Gateway unit.

After 60 seconds, a new terminal emulator session begins on the computer monitor.

- 3 After the second VxWorks banner scrolls across the screen, the following message appears: “Press any Key to start the configuration.”
 - 4 Press any key and then press **Enter**.
The default network properties screen appears.
 - 5 At the prompt, enter **P** and press **Enter** to select “change the configuration software password.”
The **Enter user name** prompt appears.
 - 6 Type the user login name for which you want to change the password and press **Enter**.
The default user name is admin. This is the user name that allows you to access the LifeSize Gateway interface.
The **Enter new password** prompt appears.
 - 7 Type the password you want the user to use to log in to the LifeSize Gateway interface and press **Enter**.
There is no default password.
 - 8 The network configuration **Main** menu re-appears.
 - 9 Enter **Q** and press **Enter** to exit.
-

CONNECTING THE LIFE SIZE GATEWAY UNIT TO THE LAN



This section describes how to connect the LifeSize Gateway unit to the Local Area Network (LAN).

Procedure

- 1 Connect the supplied LAN cable from your network hub to the 10/100BaseT Ethernet port on the front panel of the LifeSize Gateway unit. The 10/100BaseT port accepts an RJ-45 connector.
 - 2 Connect a separate ISDN or serial line to each PRI or serial port in the rear panel of the LifeSize Gateway unit. The port accepts an RJ-45 connector.
-

CONNECTING SERIAL LINES TO THE GATEWAY



You can connect the N/A to four serial lines that may support different physical standards (V.35, RS-449 or EIA-530). The system is capable of recognizing the type of cable connected.

Procedure

- 1 Connect the DB-60 male connector of the cable to the DB-60 female connector of the unit.
 - 2 Tighten the screws.
 - 3 Connect the remote connectors (V.35, RS-449, EIA-530 and RS-366) to the connectors or the connecting cable of the remote equipment
-

SERIAL GATEWAY CABLE CONNECTIONS AND PIN-OUTS

This section describes the DTE cables that you can use with the Gateway-Serial unit including the following topics:

- [Physical Description of DTE Cables](#) on page 28
- [Data Interface Cable Pin-out Configurations](#) on page 34
- [Data Interface Pin Layouts](#) on page 36
- [Signaling Interface Cable Pin-out Configuration](#) on page 39
- [Signaling Interface Pin Layout](#) on page 40

PHYSICAL DESCRIPTION OF DTE CABLES

This section describes the following DTE cables supplied with the Gateway-Serial unit:

- [V.35/RS366-DTE](#) on page 29
- [EIA449/RS366-DTE](#) on page 30
- [EIA530/RS366-DTE](#) on page 31

- EIA530/RS366-DTE- LOS on page 32
- KIV7/RS366-DTE on page 33

-
- Note**
- The **DB-25** connector provides the data interface for the EIA530/RS366-DTE and EIA530/RS366-DTE- LOS cables.
 - The **DB-37** connector provides the data interface for the EIA449/RS366-DTE and KIV7/RS366-DTE cables.
 - The **DB-25** connector provides the RS-366 signaling interface for all Gateway-Serial unit cables.
-

V.35/RS366-DTE

Figure 2-5 shows the V.35/RS366-DTE cable.

Figure 2-5 V.35/RS366-DTE Cable

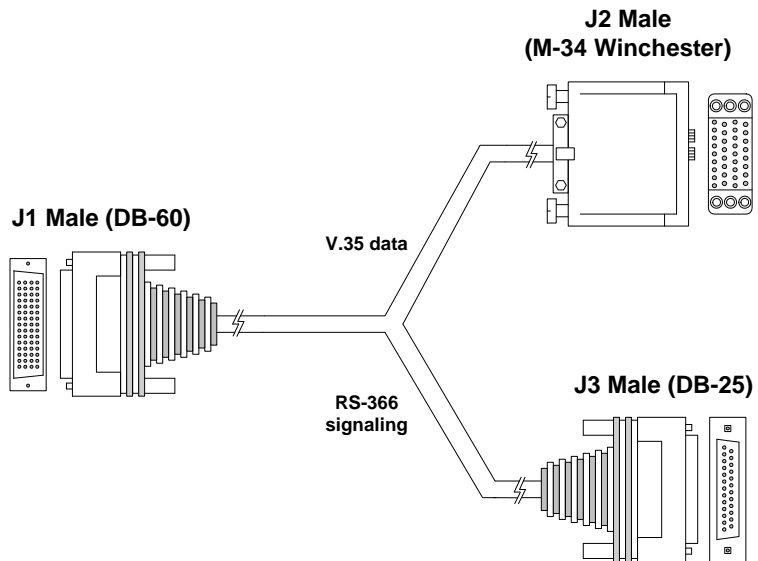

Serial Gateway Cable Connections and Pin-outs

EIA449/RS366-DTE

Figure 2-6 shows the EIA449/RS366-DTE cable.

Figure 2-6 EIA449/RS366-DTE Cable

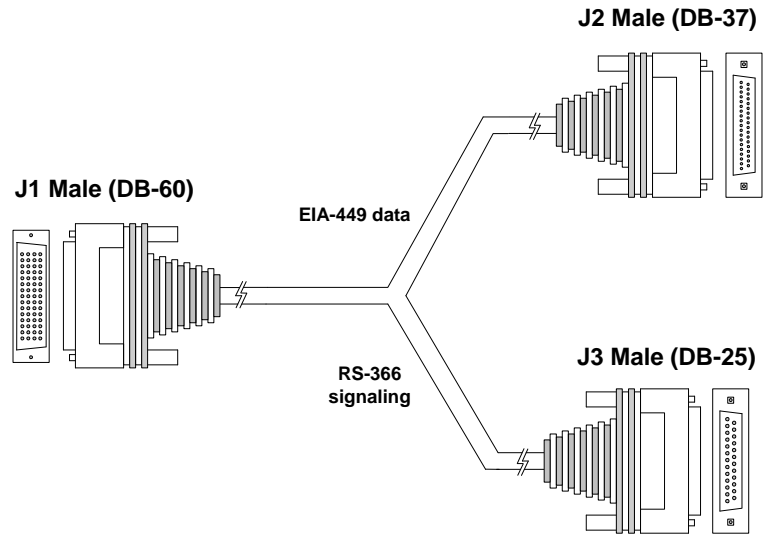

EIA530/RS366-DTE

Figure 2-7 shows the EIA530/RS366-DTE cable.

Figure 2-7 EIA530/RS366-DTE Cable

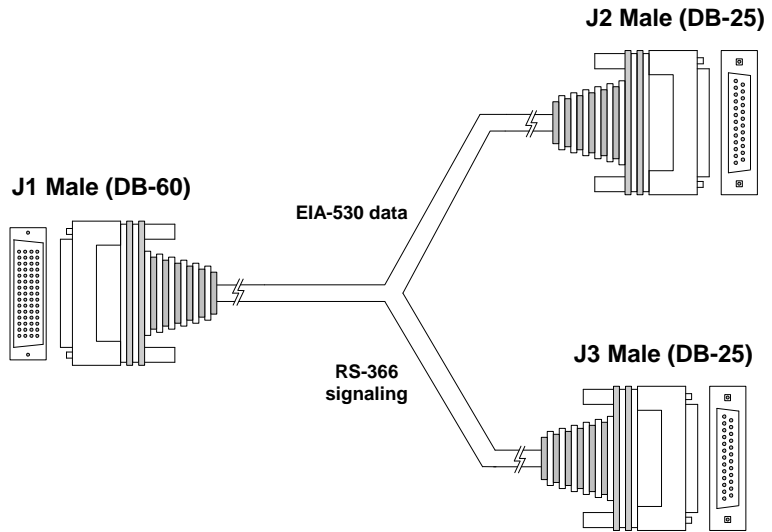

Serial Gateway Cable Connections and Pin-outs

EIA530/RS366-DTE-
LOS

Figure 2-8 shows the EIA530/RS366-DTE-LOS cable.

Figure 2-8 EIA530/RS366-DTE-LOS Cable

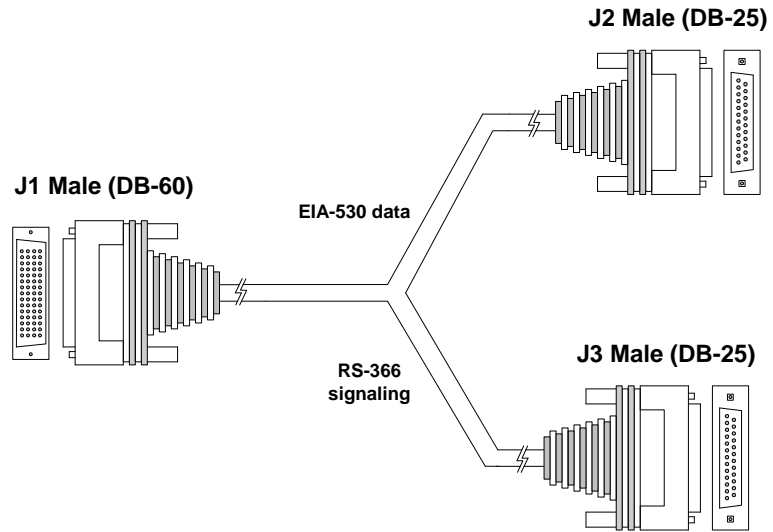

KIV7/RS366-DTE

Figure 2-9 shows the KIV7/RS366-DTE cable.

Figure 2-9 KIV7/RS366-DTE Cable

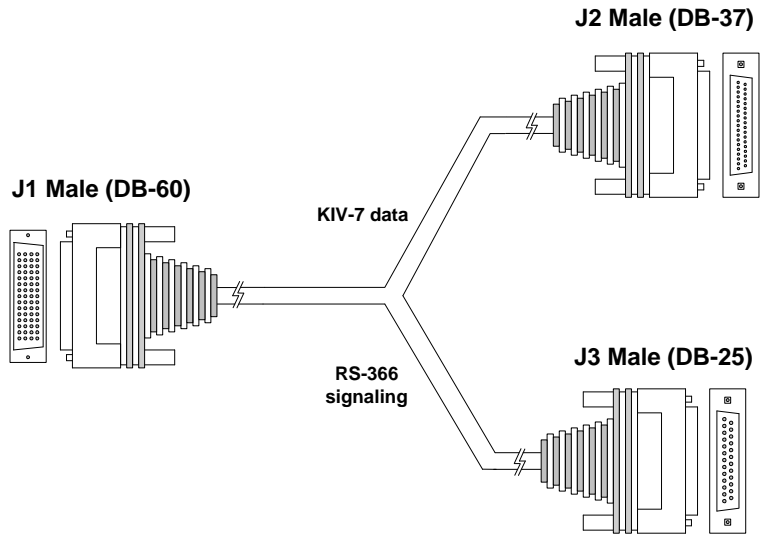

**DATA INTERFACE
CABLE PIN-OUT
CONFIGURATIONS**

Table 2-6 describes the data interface pin-out configuration for the Gateway-Serial cables.

Table 2-6 Serial Gateway Data Interface Cable Pin-out Configuration

Signal Name	Mnemonic	KIV-7 (DB-37) DTE only	EIA-449 (DB-37)	EIA-530 (DB-25)	EIA-530 LOS (DB-25) DTE only	EIA-530A LOS (DB-25) DTE only	V.35 (M-34)
Shield	—	1	1	1	1	1	A
Transmit Data	TXD A	2	4	2	2	2	P
Transmit Timing	TXC A	15	5	15	15	15	Y
Receive Data	RXD A	3	6	3	3	3	R
Request To Send	RTS A	4	7	4	4	4	C
Receive Timing	RXC A	17	8	17	17	17	V
Clear To Send	CTS A	5	9	5	5	5	D
Data Set Ready	DSR A	6	11	6	6	6	E
Data Terminal ready	DTR A	20	12	20	20	20	H
Carrier Detect	DCD A	8	13	8	8	8	F
Terminal Timing	TT A	24	17	24	24	24	U
Signal Ground	—	27	19	7	7	7	B
Transmit Data	TXD B	14	22	14	14	14	S
Transmit Timing	TXC B	12	23	12	12	12	AA
Receive Data	RXD B	16	24	16	16	16	T

Signal Name	Mnemonic	KIV-7 (DB-37) DTE only	EIA-449 (DB-37)	EIA-530 (DB-25)	EIA-530 LOS (DB-25) DTE only	EIA-530A LOS (DB-25) DTE only	V.35 (M-34)
Request To Send	RTS B	19	25	19	19	19	—
Receive Timing	RXC B	9	26	9	9	9	X
Clear To Send	CTS B	13	27	13	13	13	—
Data Set Ready	DSR B	22	29	22	22	—	—
Data Terminal ready	DTR B	23	30	23	23	—	—
Carrier Detect	DCD B	10	31	10	10	10	—
Terminal Timing	TT B	11	35	11	11	11	W
Local Loopback	LL	—	10	18	—	18	L, K
Remote Loopback	RLB	—	14	21	—	21	N
Loss of Sync	LOS unbalanced	31	36	—	—	—	—
Loss of Sync	LOS A	—	3	—	18	—	—
Loss of Sync	LOS B	—	21	—	21	—	—

Serial Gateway Cable Connections and Pin-outs

DATA INTERFACE PIN LAYOUTS

This section illustrates the pin layouts for the Gateway-Serial cable connectors.

M-34 CONNECTOR

Figure 2-10 shows the M-34 pin assignment.

Figure 2-10 M-34 Pin Layout

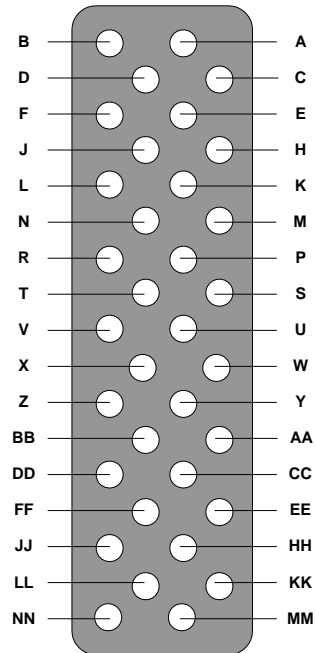

DB-37 CONNECTOR

Figure 2-11 shows the DB-37 pin layout.

Figure 2-11 DB-37 Pin Layout

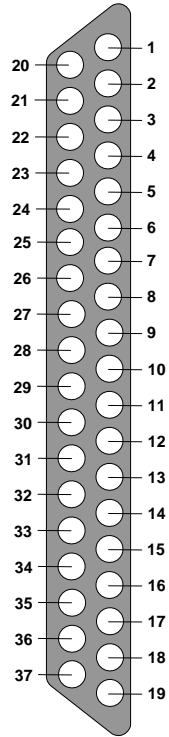

DB-25 CONNECTOR

Figure 2-12 shows the DB-25 pin layout.

Figure 2-12 DB-25 Pin Layout

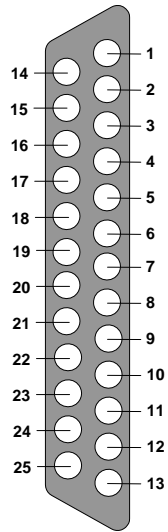

SIGNALING INTERFACE CABLE PIN-OUT CONFIGURATION

Table 2-7 describes the signaling interface pin-out configuration for the Gateway-Serial cables.

Table 2-7 Serial Gateway Signaling Interface Cable Pin-out Configuration

Signal Name	Mnemonic	RS-366 (DB-25)
Shield	—	1
Digit Present	DPR	2
Abandon Call & Retry	ACR	3
Call Request	CRQ	4
Present Next Digit	PND	5
Power Indication	PWI	6
Signal Ground	—	7
Distant Station Connection	DSC	13
Digit Signal Circuit 1	NB1	14
Digit Signal Circuit 2	NB2	15
Digit Signal Circuit 4	NB4	16
Digit Signal Circuit 8	NB8	17
Receive Common	RC	18
Send Common	SC	19
Data Link Occupied	DLO	22

Serial Gateway Cable Connections and Pin-outs

SIGNALING INTERFACE PIN LAYOUT

This section illustrates the pin layout for the Gateway-Serial signaling cable connector.

DB-25 CONNECTOR

Figure 2-13 shows the DB-25 pin layout.

Figure 2-13 DB-25 Pin Layout

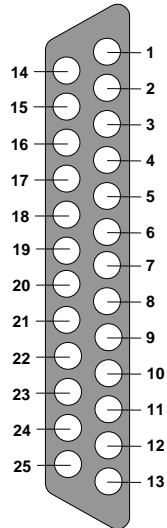

MANAGING AND MONITORING THE LIFESIZE GATEWAY UNIT

You can manage and monitor the LifeSize Gateway unit locally or from remote connections. You can also upgrade LifeSize Gateway software.

SNMP MANAGEMENT

The LifeSize Gateway unit is equipped with an SNMP agent. You can access the LifeSize Gateway unit using an SNMP management client.

LOCAL PORT MONITORING CONNECTIONS

You should access the LifeSize Gateway unit using a local port connection for preliminary configuration and monitoring.

SERIAL PORT

The LifeSize Gateway unit includes a DB-9 serial port connector and an RJ-45 serial port connector. The DB-9 serial port is used to access the boot sequence menu from a local PC. Using a terminal emulation application running on the PC, you can assign an IP address and subnet mask to the LifeSize Gateway unit. The RJ-45 serial port is used to connect a PC terminal to the LifeSize Gateway unit.

Note A special adapter cable for connecting between a standard DB-9 serial cable and the RJ-45 serial port is supplied with the LifeSize Gateway unit.

SVGA PORT

The LifeSize Gateway unit is equipped with an SVGA port for connecting to a standard PC monitor screen. The SVGA port allows you to view the operating system desktop and to monitor the applications that are active on the desktop.

PERFORMING SOFTWARE UPGRADES

You can perform software upgrades by using the LifeSize Upgrade Utility to upload files via a network or modem connection to the LifeSize Gateway unit. For more information, see the [Using the LifeSize Software Upgrade Utility chapter](#).

ACCESSING THE LIFE SIZE GATEWAY ADMINISTRATOR INTERFACE

The LifeSize Gateway Administrator is a web interface that allows you to configure general LifeSize Gateway unit settings, monitor LifeSize Gateway unit operation, create or edit services and perform maintenance.

You access the LifeSize Gateway Administrator web interface in the LifeSize Gateway unit access window by signing in as an Administrator.

You can use your web browser from any remote PC station to monitor and to configure the LifeSize Gateway unit. A web server is installed in the LifeSize Gateway unit to facilitate the use of the remote web-based monitoring and management.

Access to the LifeSize Gateway configuration interface is controlled by a user name and a password. Once you have entered the settings you want, you should upload them to the unit for them to take effect, or you can save them to a configuration file to be loaded at a later time.

Before You Begin

The following requirements are necessary to access the Gateway Administrator web interface:

- A Java-compliant browser. Microsoft Internet Explorer version 5.5 or later is recommended.
- The LifeSize Gateway unit IP address or a web link to the LifeSize Gateway unit.
- Administrator level-access
- The required user name and password.

Note For first-time installation, you must assign an IP address to the LifeSize Gateway unit using a serial port connection before you can access the web interface. For more information, see [Setting the IP Address](#) on page 23.



Procedure

- 1 Launch your browser and type the IP address or the name of the LifeSize Gateway unit.

For example, **http://125.221.23.44** or **board_name**.

The LifeSize Gateway login page appears.

- 2 Type the Administrator user name and password in the appropriate fields and click **Login**. The default global user name is *admin*. The default password is <null>. The Gateway Administrator interface appears.

Note If you try to sign in as an Administrator and another Administrator is currently signed in, the LifeSize Gateway signs you in as a **Read only** user and the words *Read Only* appear at the top of the window. **Read only** users cannot edit any of the LifeSize Gateway settings.

REGISTERING THE ONLINE HELP

The LifeSize Gateway is equipped with online help that is linked to the LifeSize Gateway Administrator web interface. The help library is stored on the LifeSize web site.

The Online Help folder available from the LifeSize Gateway CD-ROM included in the product box contains the online help library. If you wish to install the online help on a shared network location and link it to the LifeSize Gateway Administrator, perform the following steps:



Procedure

- 1 Copy the **Online Help** folder from the LifeSize Gateway CD-ROM to a shared folder on a PC on your network. For example:

```
\\myComputer\LifeSize Gateway\Online Help
```
- 2 Log in to the LifeSize Gateway Administrator interface.
- 3 In the **Online help URL** field of the Device **Web** tab, type the directory path to the help files you installed on your PC.

The path must have the form:

```
file://computerName/sharedDirectory
```

where *computerName* is the name of the computer on the network and *sharedDirectory* is the path to the **Online Help** folder on the CD-ROM. For example:

```
file://myComputer/LifeSize Gateway/Online Help
```

Registering the Online Help

- 4 Click **Upload** in the LifeSize Gateway Administrator toolbar, followed by **Refresh**.
 - 5 You may need to log out and log back in to the LifeSize Gateway Administrator for the change to take effect.
-

3

USING THE LIFESIZE SOFTWARE UPGRADE UTILITY

This section describes the LifeSize Software Upgrade Utility, and includes the following topics:

- [Introduction](#)
- [Launching the Utility](#)
- [Upgrading Software](#)

INTRODUCTION

The LifeSize Software Upgrade Utility is an interactive GUI interface that enables you to upgrade LifeSize software installed on LifeSize Gateways.

The LifeSize Software Upgrade Utility enables you to select files to be uploaded via a network or modem connection to the LifeSize Gateway. You can select either to perform a typical upgrade which includes all the new files or a customized upgrade which enables you to select which files to upload.

The upgrade files are uploaded and then burned into the memory of the LifeSize Gateway.

Before You Begin

LifeSize Gateways automatically save configuration settings before a software upgrade takes place. However, it is recommended that you save all configuration information using the Export button in the LifeSize Gateway web interface toolbar. You can retrieve all these settings after the software upgrade is complete by using the Import button in the LifeSize Gateway web interface toolbar.

LAUNCHING THE UTILITY



This section describes how to install and launch the LifeSize Software Upgrade Utility.

Procedure

- 1 Download the *UpgradeUtility.exe* file from the LifeSize web site at www.lifesize.com/service.
 - 2 Double click the UpgradeUtility.exe file to run the Software Upgrade Utility.
The upgrade files are extracted and the **Upgrade Utility** dialog box appears.
-

UPGRADING SOFTWARE



This section describes how to use the Software Upgrade Utility to upgrade LifeSize software installed on LifeSize Gateways.

Procedure

- 1 In the **General Information** section of the **Upgrade Utility** dialog box, enter the IP address of the LifeSize Gateway you want to upgrade.
 - 2 In the **Login Information** section, enter the administrator user name and password for the target LifeSize Gateway, as configured in the LifeSize Gateway network configuration settings.
 - 3 (Optional) Modify the read and write community settings for the target LifeSize Gateway as follows:
 - Click **Customize SNMP Settings**.
The **Customize SNMP Settings** dialog box displays.
 - Enter the required read community and write community values.
-

Note We recommend that you modify the default settings for security purposes.

- Click **OK** to return to the **Upgrade Utility** dialog box.
- 4 (Optional) Select the components of the target LifeSize Gateway you want to upgrade as follows:
 - Click **Customize**.
The **Customize** dialog box appears.
 - Check the LifeSize Gateway components you want to upgrade in the **Select the components you want to upgrade** list.
 - Click **OK** to return to the **Upgrade Utility** dialog box.
- 5 Click **Upgrade** to upgrade all components of the LifeSize Gateway software (or only those components you manually selected via the **Customize** option).
The LifeSize Software Upgrade Utility informs you whether or not the upgrade is successful.

Note When the upgrade is complete, the LifeSize Gateway automatically resets itself and starts operation with the new software version.

Upgrading Software

4

CABLE CONNECTIONS AND PIN-OUTS

This section describes the pin-to-pin and pin-out configurations of the connectors and cables of the LifeSize Gateway unit, including the following topics:

- [Unit RS-232 9-Pin Serial Port](#)
- [RJ-45 8-Pin IP Network Port](#)
- [RJ-45 Serial Port Adapter Cable](#)

UNIT RS-232 9-PIN SERIAL PORT

Table 4-1 describes the LifeSize Gateway unit RS-232 9-pin D-type serial port pin-out configuration.

Table 4-1 RS-232 9-pin D-Type Serial Port Pin-out

Pin	Function	I/O
1	NC	
2	RXD	Input
3	TXD	Output
4	NC	
5	GND	
6	NC	
7	NC	
8	NC	
9	NC	

RJ-45 8-PIN IP NETWORK PORT

Table 4-2 describes the pin-out configuration of the RJ-45 IP network port.

Table 4-2 Pin-out Configuration of the RJ-45 IP Network Port

Pin	Function	I/O
1	TXD+	Output
2	TXD+	Output
3	RXD+	Input
4	NC	
5	NC	
6	RXD-	Input
7	NC	
8	NC	

RJ-45 SERIAL PORT ADAPTER CABLE

Table 4-3 describes the pin-to-pin configuration of the RJ-45 to DB-9 adapter cable used to connect a PC terminal to the RJ-45 serial port. This cable is provided with the LifeSize Gateway unit.

Table 4-3 *Pin-to-Pin Configuration of the RJ-45 to DB-9 Adapter Cable*

RJ-45 (Male)	DB-9 (Female)	Function
1	NC	
2	NC	
3	3	TXD
4	NC	
5	5	GND
6	2	RXD
7	NC	
8	NC	

ISDN PORT

Table 4-4 describes the ISDN Port RJ-45 connector pin-out configuration.

Table 4-4 *ISDN Port RJ-45 Connector Pin-out*

Pin	Function
1	RXD +
2	RXD -
3	NC
4	TXD +
5	TXD -
6	NC
7	NC
8	NC

ISDN Port

5

TECHNICAL SPECIFICATIONS

This section provides technical specifications for the LifeSize Gateway.

TECHNICAL SPECIFICATIONS TABLE

Table 5-1 *LifeSize Gateway Unit Technical Specifications*

Unit Dimensions	<ul style="list-style-type: none">■ Height: 1U (1.75 inches or 44.45 mm)■ Width: 17.25 inches (438.15 mm)■ Depth: 10 inches (254 mm)■ Weight: 4.45 kg (9.81 lbs)—may vary according to configuration
<hr/>	
LED Indicators	
Front panel	<ul style="list-style-type: none">■ ETHERNET:<ul style="list-style-type: none">□ Link□ Connection Speed■ GK■ D-Ch■ ALRM■ ACT
Rear panel (Gateway-PRI)	<ul style="list-style-type: none">■ ACT■ D-Ch■ ALRM
Rear panel (N/A)	<ul style="list-style-type: none">■ ACT 1 to 4

Table 5-1 LifeSize Gateway Unit Technical Specifications (continued)

Rear panel (Gateway-Serial)	<ul style="list-style-type: none"> ■ ACT 1 to 4 ■ ALRM 1 to 4
Push Buttons	<ul style="list-style-type: none"> ■ RST (front panel)
Communication Interfaces	
Front panel	<ul style="list-style-type: none"> ■ Ethernet 10/100 Mbps auto-negotiate speed select ■ Asynchronous serial port RS-232 connected via 9-pin D-type connector ■ RJ-45 serial port (for video processing module) ■ SVGA port (for video processing module) ■ USB connector (for video processing module)
Rear panel (Gateway-PRI)	<ul style="list-style-type: none"> ■ 2 x ISDN E1/T1 PRI port: <ul style="list-style-type: none"> □ T1 mode <ul style="list-style-type: none"> Channels: 23B + 1D Clock rate: 1.544 Mbps Framing: F4, F12, ESF no CRC, ESF, F72 Encoding: NRZ, AMI-B7, B8ZS Line impedance: 100Ω □ E1 mode <ul style="list-style-type: none"> Channels: 30B + 1D Clock rate: 2.048 Mbps Framing: Double framing, CRC4, Extended CRC4 Encoding: NRZ, CMI, AMI, HDB3 Line impedance: 120Ω
Rear panel (Gateway-Serial)	<ul style="list-style-type: none"> ■ 4 x serial ports
Chipset	<ul style="list-style-type: none"> ■ PowerPC MPC755 32-bit RISC microprocessor running at 400MHz or more ■ MPC8260 secondary microprocessor running at 200/133MHz or more
Operating System	<ul style="list-style-type: none"> ■ RTOS, VxWorks 5.4

Table 5-1 *LifeSize Gateway Unit Technical Specifications (continued)*

Memory	<ul style="list-style-type: none"> ■ 32 MB on-board flash memory for field upgrades, supports up to 64 MB ■ 1 MB L-2 Cache at 200 MHz or more ■ 128 MB SDRAM, supports up to 256 MB
Failsafe	<ul style="list-style-type: none"> ■ Watchdog timer built in
Power Supply	<ul style="list-style-type: none"> ■ Input 100-240VAC autoswitched ■ Output + 3.3VDC, + 5VDC, + 12VDC ■ Maximum power load 150W

Technical Specifications Table

INDEX

A

- access control 3
- ACT LED 18, 19, 20
- Administrator interface 42
- ALRM LED 18, 19, 20
- audio codecs 5
- audio transcoding 5
- auto-boot 22

B

- bandwidth
 - call overhead 15
 - resource allocation 16
 - supported 6
- bonding
 - calls 8
- boot configuration menu 22

C

- cables
 - DCE 28
 - DTE 28
 - EIA449/RS366-DTE 30
 - EIA530/RS366-DTE 31
 - EIA530/RS366-DTE-LOS 32, 33
 - KIV7/RS366-DTE 33
 - RJ-45 8-pin IP network port 50
 - RJ-45 serial port adapter 51
 - RS-232 9-pin serial port 50
 - V.35/RS366-DTE 29
- call bandwidth overhead 15
- call handling

- capabilities 7
 - PRI gateway capacity 15

- chipset 54
- communication interfaces 54
- conceal caller ID 4
- connectors
 - Ethernet 18
 - PORT 20
 - PRI line 19
 - serial port 18, 41

D

- data collaboration 2
- DB-60 20
- DB-9 7, 18, 41
- D-Ch LED 19
- default extension 3
- diagnostics 2
- dial plan 3
- DID 3
- direct dialing 3
- downspeeding 4
- DTE 28
- DTMF 3
- dual video 3

E

- E1/T1 11, 16
- EIA-530 28
- encryption 5
 - interoperability 8
 - serial gateway 13

- via satellite 13
- Ethernet
 - 10/100Base-T 7
 - connector 18
- Ethernet LED 18

F

- failsafe 55
- fast start 4
- feature summary
 - general features 2
- first-time installation 42
- front panel 18

G

- GK LED 18

H

- H.239 5
- H.243 5
- H.323
 - fast start 4

I

- initial configuration 22
- installation requirements 20
- interoperability 2
- IP address assign 24
- IP network connection 5, 7
- ISDN
 - connection failure 4
 - rollover 4
- IVR 3
 - internal capacity 8

L

- LAN 18, 27
 - 10/100Base-T 7
- leased lines

- serial gateway 14
- LED indicators 18, 19, 20, 53
- line quality 7
- local
 - configuration 41
 - monitoring 41

M

- media + signaling combinations 7
- media protocols 7
- memory 55
- MSN 3
- multimedia conferencing 9
- multipoint conferencing 10

N

- network load balancing 2
- Network Specific Facility (NSF) 4

O

- online help 43
- operating system 54

P

- package contents 21
- password
 - default login user 26
- peer-to-peer
 - connectivity 5, 16
- physical description
 - gateway 18
- pin layout
 - DB-25 38, 40
 - DB-37 37
 - M-34 36
 - serial gateway cable connectors 36
 - serial gateway signaling cable connector 40
- pin-out configuration
 - RJ-45 IP network port 50

- RS-232 9-pin D-type serial port 50
- serial gateway data interface cable 34
- serial gateway signaling interface cable 39
- pin-to-pin configuration
 - RJ-45 to DB-9 adapter cable 51
- point-to-point conferencing 10
- PORT connectors 20
- ports
 - IRJ-45 8-pin ISDN 51
 - RJ-45 IP 50
 - RJ-45 serial 51
 - RS-232 9-pin serial 50
 - supported 5
 - SVGA 41
- power supply 55
- PRI
 - call handling capacity 15
 - connecting gateway directly to central office switch 12
 - connecting gateway to a PBX 12
 - interface features 8
 - ISDN connections 11
- PRI LINE connectors 19
- push buttons 54

Q

- Q.931 3
- Quality of Service (QoS) 2

R

- rack mounting 21
- rear panel 19, 20
- remote
 - management 41
- requirements 24
 - installation 20
- RJ-45 18, 19, 41
- rollover 4
- routing 3
- RS-232
 - DTE 9-pin D-type connection 7

- RS-449 28
- RST button 18, 54

S

- serial control port 7
- serial lines 28
- serial port connector 18, 41
 - DB-9 41
- setup procedures
 - access Administrator interface 42
 - change default password 26
 - connect a serial cable 28
 - connect to a PC 23
 - connect unit to LAN 27
 - mount unit on a 19-inch rack 21
 - set IP address 24
- signaling protocols 7
- SNMP
 - management 2, 41
 - trap servers 4
- software upgrade utility procedures
 - install and launch 46
 - use utility 46
- software upgrades 41
- SVGA 41
- switch information 8

T

- T.120
 - data collaboration 2
- TCS4 3

U

- unit dimensions 53
- upgrade software 45

V

- V.35 28
- video conferencing protocols 5
- video protocols 6

video resolutions 6

W

web-based management 2